

Generator Set Instruction Manual
Contents

Chapter I. Safety Guidelines	1
1.1 General Rules & Objective Requirements	1
1.2 Transportation And Handling	1
1.3 Fire And Explosion Protection	1
1.4 Electrical Hazard Warning	2
1.5 Emergency Treatment for Electric Shock	2
1.6 Other Warnings	2
Chapter II. Introduction	3
2.1 Diesel Engine	4
2.1.1 Cooling System of Engine	4
2.1.2 Air Intake & Exhaust System of Engine	4
2.1.3 Fuel System & Lubrication System of Engine	5
2.1.4 Electrical Control System of Engine	5
2.2 AC Generator	6
2.2.1 Definition of Generator Power	6
2.2.2 Excitation System	6
2.2.3 Automatic Voltage Regulator	7
2.3 Base Frame And Fuel Tank of Genset	7
2.4 Control System of Genset	7
2.5 Main Output Switch of Genset	8
Chapter III. Installation	9
3.1 Installation Overview	9
3.2 Selection of Installation Location	9
3.3 Foundation	9
3.4 Fixation and Vibration Isolation	10
3.5 Connection of Exhaust System	11
3.6 Connection of Fuel System	12
3.7 Installation of Cooling And Ventilation System	12
3.8 Electrical Connection	15
3.9 Noise Reduction Project	16
Chapter IV. Testing And Commissioning	18
4.1 Checks And Precautions before Testing	18
4.2 Commissioning under Rated Conditions	19
Chapter V. Running In	21
5.1 Principles	21
5.2 Steps of Running In	21
5.3 Expected Performance after Running In	21
Chapter VI. Maintenance during Normal Operation	22
6.1 Daily Operation Report of Genset	22
Chapter VII. Service	23
7.1 Guidelines for Service	23
7.2 Maintenance & Service Schedule	23
Chapter VIII. Troubleshooting	26
8.1 Diesel Engine	26

Generator Set Instruction Manual
Contents

8.2 AC Generator.....	32
Appendix A: Technical Specifications of Fuel, Lubricant & Cooling System.....	33
Appendix B: Storage, Testing & Maintenance of Lead-Acid Battery.....	35
Appendix C: Use of Genset under Harsh Conditions.....	37

Chapter I. Safety Guidelines

1.1 General Rules & Objective Requirements

Prior to operating the genset, please read through this User Manual, be familiar with the instructions and the equipment, and carry out installation, commissioning, operation and maintenance in accordance with the relevant requirements. The maintenance shall be carried out by the qualified, meticulous and experienced maintenance staff, since failure to follow the general rules and safety precautions may lead to serious consequences, such as, equipment shutdown, mechanical damage or person injury, resulting in unnecessary loss. Therefore, the genset is provided with safe and effective protection; besides, both operating and maintenance staff shall strictly comply with the operation instructions and relevant procedures for safe and efficient running of the equipment.

Warning※

Failure to follow the instructions in the User Manual may increase the risk of accidents.

The installation and application of this genset must conform to the requirements of relevant national and local laws and regulations.

1.2 Transportation And Handling

The genset is available in either open type or silent type, of which, the silent type is available in two versions, i.e., standard model and containerized model. Appropriate precautions against collision with other objects shall be taken for the genset during transportation. For the open type, it is forbidden to place any articles on the top of the genset. To facilitate hoisting and movement, the genset is generally designed with slots at the base frame to accommodate hoisting mechanism and forklift.

Warning※

Prior to hoisting, check if the lifting facilities are in good conditions and make sure to use appropriate slings.

Never use the lifting eyes on the generator and engine to lift the genset up.

For the sake of safety, it is forbidden to stand or walk under the lifted genset.

1.3 Fire And Explosion Protection

- No open flame or spark is allowed near the fuel tank and battery of the genset, because both fuel oil (gas) and hydrogen emitted during battery charging are explosive;
- Except that the fuel tank is separated from the genset, it is forbidden to refill the fuel tank when the engine is running, because it presents a potential fire hazard when fuel contacts a hot engine or exhaust gas;
- The generator room shall be equipped with appropriate firefighting equipment.

1.4 Electrical Hazard Warning

- The generator can only be connected to loads corresponding to its electrical properties and rated output. Overload running is strictly forbidden;
- Conform to relevant prevailing national and international statutory electrical specifications. The electrical equipment shall be installed by an eligible and qualified electrician. When the power switch is turned on, set up a warning sign to avoid accident;
- Do not connect the genset directly to the electric system of the building, which may result in electric shock or generator damage due to impact of mains supply. A safe switch shall be used in the connection between the genset and mains supply system;
- Proper neutral earthing must be carried out to protect against voltage rise and undetected earthing fault;
- To avoid electric shock: the power switch must be turned off before removing the protective shield or touching the electrical equipment; before approaching the metal or cement floor around the electrical equipment, place a dry wood plank on the floor and cover it with an insulating rubber mat; do not touch the electrical equipment when wearing wet clothes (especially wet shoes) or when skin is wet;
- Be very careful when working on live equipment, because high voltage will lead to personal injury or death. Any unauthorized alteration of interlocks is not allowed;
- Before putting the generator into operation, be sure to use a 500V megohmmeter to measure the insulation resistance of output cable to make sure it is no less than $2M\Omega$.

1.5 Emergency Treatment for Electric Shock

Do not touch the electric shock sufferer before the power supply is completely disconnected. In case of electric shock, switch off the genset and disconnect the power supply immediately, and conduct emergency treatment for the sufferer. If the sufferer has stopped breathing, apply cardiopulmonary resuscitation (CPR) immediately and keep on this treatment, meanwhile, call for medical or first-aid assistance. Before the medical assistance arrives, do not give up onsite emergency treatment, do not give up rescue based on arbitrary judgment of death due to respiratory arrest or pulse stoppage.

1.6 Other Warnings

- When working near moving parts or electrical equipment, do not wear loose clothes or jewelry, since loose clothes may be caught by the moving parts and jewelry may cause short circuit leading to electric shock or fire;
- Make sure the fasteners of the genset are tightened. Provide proper protective guards for the fan or conveyer belt;
- Before repairing or maintaining the genset, be sure to disconnect the starting battery, beginning with the negative electrode, to avoid accidental starting of the engine;
- When the genset is running, never disconnect the battery from the charging connection, otherwise, the battery charging system may be damaged;
- When working around the genset and associated equipment, the operators shall wear appropriate personal protections, such as, protective devices to prevent them from direct contact with coolant additive or battery electrolyte, ear protection that protect them from constant exposure to big noise, etc.

Chapter II. Introduction

The following is the structural drawing of standard open-type genset.

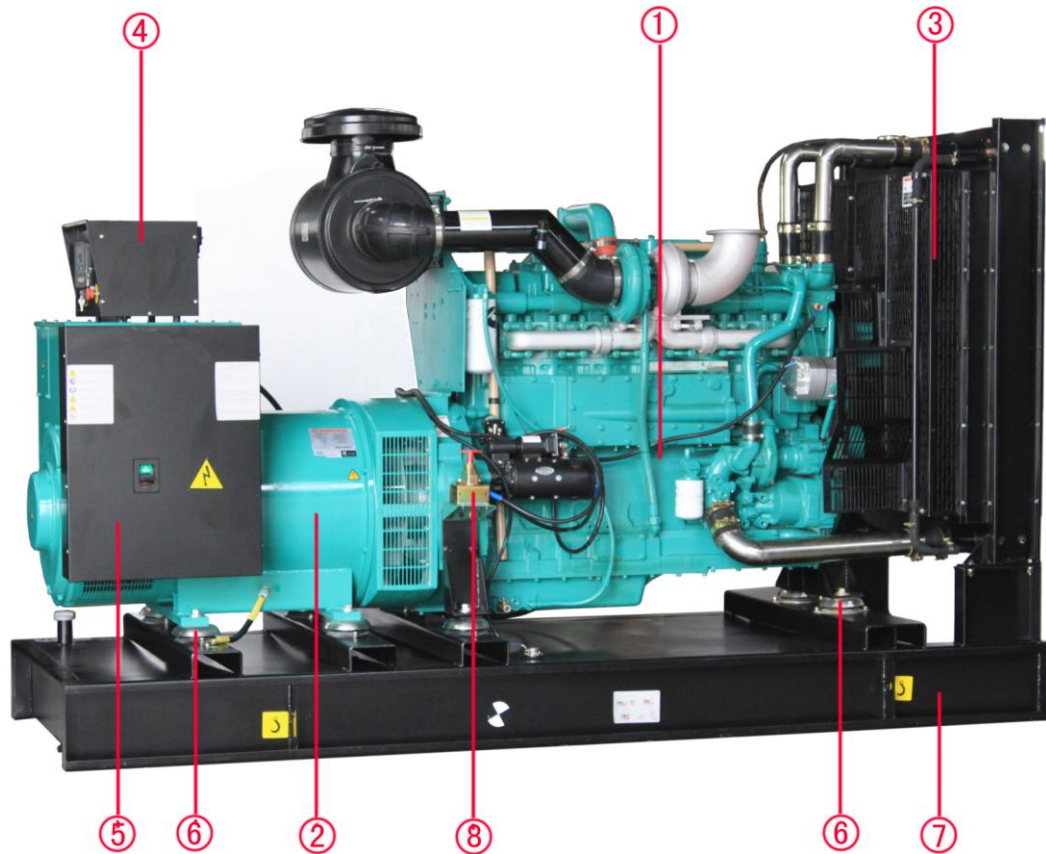

1. Diesel engine
2. Generator
3. Radiator
4. Control panel
5. Switch box Base frame
6. Internal vibration damping
7. Base frame
8. Solenoid Switch

2.1 Diesel Engine

The genset is equipped with heavy-duty industrial diesel engine, which provides sufficient power for the generator, while guaranteeing the safe and reliable performance of genset thanks to its multiple fuel control systems. The electronic fuel injection system with synchronization operation function enables accurate active load sharing for mains parallel operation.

2.1.1 Cooling System of Engine

Considering that a lot of heat is generated during running, a cooling system is provided to guarantee the safe and stable running of the diesel engine. The standard engine is equipped with radiator. The fan is driven by the engine to cool down the radiator and the cooling water is recycled through the thermostat.

The following three cooling systems are available; please refer to Chapter III for details:

- Engine mounted (standard) radiator
- Remote mounted radiator
- Engine mounted heat exchanger

2.1.2 Air Intake & Exhaust System of Engine

During operation of the genset, the engine shall be supplied with sufficient fresh air. Several ways of intake are available for the diesel engine, including: turbocharged, turbocharged & intercooled, twin turbocharged & intercooled, and charge air cooling. The air intake system consists of air filter, intake resistance indicator, turbocharger, intercooler (charge air cooling) and cylinder head intake duct.

Fresh air is filtered by the air filter, boosted by the turbocharger, then cooled via the intercooler and finally fed into the cylinder.

The turbocharger (supplied as standard for some model) can increase both intake pressure and air flow to optimize air-fuel ratio, improve combustion conditions and increase engine power, helping the engine maintain high efficiency when operating at high altitude (altitude compensation).

Warning

- Fume exhausted by the engine is poisonous, thus, the exhaust system must be installed in strict conformity with relevant regulations and be maintained in good conditions so that there is no leak on the exhaust duct or no return gas into the generator room or building;
- Good ventilation is required for the equipment;
- When the genset is running, it is forbidden to touch the exhaust pipe, radiator and hot parts, as well as hot oil, cooling water and exhaust gas to prevent scalding;
- When the genset is running, do not open the pressure cap of the radiator or heat exchanger, which can be opened only after the genset has cooled down.

2.1.3 Fuel System & Lubrication System of Engine

2.1.3.1 Fuel system of engine

The fuel system is to inject high-quality atomized diesel at a certain rate, which shall be fixed in terms of feeding time, quantity and pressure, into the cylinder according to the operating demands of the diesel engine, so as to realize quick and uniform mixing with air and good combustion. Therefore, the fuel system plays a vital role in the good performance of diesel engine.

The fuel quality is also very important. The diesel engine must be provided with sufficient and quality diesel. The diesel must be clean, at a temperature no less than 65°C, with enough calorific value, and free of paraffin wax, water or other corrosive liquid, or too much air. Before being drawn into the daily fuel tank, the diesel must be pretreated with 48 hours of sedimentation. The diesel stored in the standby fuel tank shall be refreshed within 18 hours, or an adequate amount of anti-corrosion agent shall be added, but it is strongly recommended not to use anti-corrosion agent since it will reduce fuel efficiency and starting performance of the genset.

2.1.3.2 Lubrication system of engine

The lubrication system is to deliver a fixed amount of clean, high-quality lubricating oil of proper viscosity to various essential parts, exerting a very significant influence on the reliable and lasting performance of the diesel engine.

Main functions:

Reducing wear of parts and friction resistance;

Cooling and cleaning lubricated surface;

Rust protection for the positions with oil film;

Sealing;

Buffering and absorbing vibration;

Providing hydraulic medium.

2.1.4 Electrical Control System of Engine

The diesel engine is equipped with starting battery and starter motor. The capacity and voltage of the starting battery shall match with the starter motor voltage.

The engine is equipped with oil pressure sensor, cooling water temperature sensor and speed sensor to provide information about the engine working status for the genset control system.

2.2 AC Generator

The genset relies on an IP23 (standard) or IP44 (option) or IP55 (option) brushless generator to deliver output power.

2.2.1 Definition of Generator Power

Continuous power S1 at 40°C - according to IEC60034-1 Definition

-- The generator operates with a constant load at a certain insulation level, of which, 1 hour of overload is allowed per 12 hours.

Standby power at 40°C

-- When operating with a constant load without overload, the generator can operate 500 hours at most per year, of which, the temperature rise over class H is allowed.

Standby power at 27°C

-- It operates under the same conditions as standby power at 40°C, but at the ambient temperature as low as 27°C, of which, the output power and temperature rise can be increased accordingly.

Note: when operating at the altitude above 1000M, power correction must be made, see the table below for details.

Multiply the corresponding correction factor in the table by the rating power:

Ambient temperature						
Altitude	25°C	40°C	45°C	50°C	55°C	60°C(*)
0 ~ 1000 m	1.045	1.000	0.970	0.940	0.910	0.880
1001 ~ 1500 m	1.010	0.970	0.940	0.910	0.880	0.850
1501 ~ 2000 m	0.980	0.940	0.910	0.880	0.860	0.830
2001 ~ 2500 m	0.950	0.910	0.880	0.860	0.830	0.800
2501 ~ 3000 m	0.910	0.870	0.840	0.820	0.790	0.770

2.2.2 Excitation System

Several excitation modes are available for the generator of the genset.

Self & shunt excitation system: w/o short-circuit current withstanding capability.

AREP auxiliary winding/PMG permanent magnet excitation: with short-circuit current withstanding capability, 10s, 300% rating current.

2.2.3 Automatic Voltage Regulator

The generator is equipped with automatic voltage regulator (AVR) which enables sound voltage regulation via the transistor. The AVR model varies according to the generator excitation system. The AVR has an interface for external potentiometer to facilitate voltage regulation.

2.3 Base Frame And Fuel Tank of Genset

The genset is fixed onto a rugged steel base from. For the open type, the base frame is designed with hoisting mechanism to facilitate handling by a hoist system. For some models, the base frame is provided with slots for the forks of forklift and fuel tank (for 8-hour full-load operation). The fuel tank has a baffle inside to prevent diesel from intense sloshing during handling of the genset.

2.4 Control System of Genset

The stand-alone and synchronization control systems have diversified, intelligent functions. The control system includes a charger for the starting battery, which will charge up the battery when the genset is in standby mode. After the genset is started, it is the engine charger's turn to charge up the battery. The control system features several self-starting modes, automatic mains failure (AMF) control function and remote signal starting function. The specific configuration can be selected by the users according to individual demands. In addition to the stand-alone self-starting function, the synchronization control system is also provided with automatic calling function to call out the next backup genset as the load capacity increases. When the load decreases, it enables automatic splitting and unloading of gensets. The system can be provided with soft transfer of load as well: in case of mains failure, it automatically start the gensets; when the mains supply recovers, it will realize automatically synchronization, and then splitting, unloading and stopping. Both stand-alone and synchronization control systems can be equipped with remote monitoring via the following main methods:

- 1. Main module + PC monitoring (via RS232, RS485, communication interfaces)**
- 2. Main module + secondary module (to realize both local and remote monitoring and operating)**
- 3. Main module + touch screen (based on the standard MODBUS communication protocol)**
- 4. Main module + GPRS MODEM (to enable alarm and control via cell phone)**
- 5. Main module + wireless network monitoring module (to realize internet and satellite monitoring)**

Note: RS232 transmission range: 15 m; RS485 transmission range: 1200 m.

Wherein, The stand-alone control module has the following main functions:

- 1. Display of engine parameters: engine RPM, oil pressure, water temperature, fuel level and battery voltage;**
- 2. Display of generator parameters: frequency, three-phase voltage (L-L, L-N) and current;**
- 3. Display of genset power parameter: KVA, KW, PF, KVAR, KWh;**
- 4. Display of mains parameters: frequency, three-phase voltage (L-L, L-N);**
- 5. Multiple custom input and output ports;**
- 6. Communicate with the engine control unit (ECU) via CAN interface to collect data, monitor the engine operating state and provide protections;**
- 7. Alarms for high water temperature, low oil pressure and high / low RPM of engine;**
- 8. Alarms for high / low frequency, high / low voltage, phase loss, over-current, over-power, three-phase unbalance of generator;**
- 9. Programs configurable via control panel or software;**
- 10. Event log;**
- 11. Manual and Auto modes.**

The synchronization control system is provided with the following functions, in addition to all functions of the stand-alone control system:

- 1. Automatic multi-unit calling function;**
- 2. Acquisition and analysis of multi-unit data, e.g., total power, power distribution ratio;**
- 3. PLC logical capability;**
- 4. Automatic speed and voltage regulation;**
- 5. Load sharing;**
- 6. Automatic retrieval of synchronization;**
- 7. Multi-language support;**
- 8. Automatic start-up.**

2.5 Main Output Switch of Genset

The genset is equipped with molded case circuit breaker (MCCB) or frame-type air circuit breaker (ACB) (three-pole circuit breaker is supplied as standard, unless specially requested). The main output switch of the genset is provided with circuit breaker based on the standby power and calculated current. Besides, optional motor-driven operating mechanism can be supplied according to the users' demands, to realize automatic switching and automatic recovery of genset power transmission system (for ACB, the motor-driven operating mechanism is supplied as standard). According to the users' power supply system, the ACB with appropriate breaking capacity and protections is selected.

Chapter III. Installation

3.1 Installation Overview

The following factors must be taken into consideration prior to installation:

- Levelness, load capacity and vibration transmission characteristics of the foundation;
- Sufficient cooling air supply;
- Sufficient fresh air intake;
- Cooling air discharge;
- Engine exhaust emission;
- Electrical connection;
- Operation and maintenance space;
- Noise standard;
- Installation of vibration absorber.

3.2 Selection of Installation Location

The installation location of the genset depends on the positions of other related systems, such as, ventilation duct, exhaust duct, wiring, fuel pipes, etc. The genset shall be as close to the main power switchgear as possible.

3.3 Foundation

Sufficient space must be reserved around the genset foundation for future maintenance operation. Each side of the genset shall be at least 1.5m away from the wall, except where the radiator is located. In general, the height of the generator room shall be over 4.5m, with the ceiling being 1.5m or more away from the genset top, which is the minimal space required for ventilation and hoisting operation.

To be Mounted on the concrete floor

- If the genset will be mounted on the concrete floor, a concrete foundation for the genset shall be prepared on the floor.
- The concrete foundation shall be of reinforced concrete structure and withstand a 28-day pressure test at above 2500psi (173kpa). The concrete foundation shall be at least 6 inches (150mm) above the floor and extends for at least 6 inches (150mm) from every side of the genset base frame. J-shaped or L-shaped anchor bolts shall be embedded in the concrete foundation to anchor the genset or damping pads.

To be mounted on the vibration isolation foundation

If the ambient environment is extremely sensitive to vibration or noise, the genset shall be mounted on a special vibration isolation foundation to reduce vibrating impact on the building. The anti-dynamic load capacity of the vibration isolation foundation shall be at least twice the weight of the genset (the fuel weight in the fuel tank may be excluded).

Notes:

- The vibration isolation foundation shall extend for at least 150 – 300mm from every side of the genset base frame, in this way, the length (L) and breadth (B) of the vibration isolation foundation is determined.
- The vibration isolation foundation shall be 20 – 300mm above the floor.

The depth (H) of the vibration isolation foundation is calculated according to the following formula:

$$H = K \times G / d \times (B + 0.4) \times (L + 0.4)$$

d — Cement density, normally 145lbs/ft³(2400kg/m³);

K — Times of the genset weight, normally 2;

G — Gross genset weight, in kg;

B — Breadth of the foundation, in m;

L — Length of the foundation, in m.

For example, AP900 genset: length 4.3m, breadth 1.8m, gross weight 5800kg;

$$\text{Foundation depth: } H = (2.0 \times 5800) / (2400 \times 4.7 \times 2.2) = 0.467\text{m}$$

- Appropriate space shall be reserved along the edge of the vibration isolation foundation to allow for expansion at low temperature.
- The reinforced concrete in the vibration isolation foundation must withstand a 28-day pressure test at above 2500psi(173kpa).
- The pressure on the floor produced by the total weight of the genset, fuel and vibration isolation foundation shall be lower than 96kPa.
- J-shaped or L-shaped anchor bolts shall be provided for the vibration isolation foundation to anchor the genset base frame and damping pads.
- If the genset is mounted on the floor, the floor shall be able to accommodate both static and dynamic loads of the genset and a safety factor of 1.5 shall be ensured. Certain vibration dampers shall be inserted between the genset base frame and the floor.

Note:

The foundation for the genset must be rigid and smooth. The concrete floor usually satisfy the physical requirement, thus, no further treatment is required.

3.4 Fixation and Vibration Isolation

For some genset with built-in vibration dampers, the rubber dampers inserted between the genset body and the steel chassis can provide vibration isolation effects. Therefore, unless in extremely sensitive environment where additional vibration isolators are needed between the steel chassis and the installation foundation, the steel chassis can be directly fixed onto the installation foundation.

For other genset without built-in vibration dampers, vibration isolators must be provided between the steel chassis and the installation foundation for vibration absorption.

The vibration isolators can reduce the vibration and noise transmitted to the installation foundation. Several vibration isolators can be used, among which, the spring damper works best with a vibration isolating efficiency of 98%, the fiberglass damper 75%~85%, and the rubber damper 50%~80%. For the places where

the geology or environment requires better anti-vibration requirements, 25~30mm damping ditches must be set around the installation foundation and an extra damping layer must be set to the bottom of the foundation. The damping layer, about 200mm thick, is a mixture of cement, cinder and bitumen laid on top of the tamped bottom of the foundation. The concrete installation foundation is built on top of the damping layer. The steel base frame of the genset shall be attached to the ground with anchor bolts to prevent displacement.

3.5 Connection of Exhaust System

The exhaust system is designed to discharge exhaust gas into the atmosphere in a secure manner and keep exhaust gas, dust and noise from the buildings and crowds. For genset, the backpressure in the exhaust system must be carefully considered to achieve the rated power output. Requirements for the exhaust system include:

- The exhaust backpressure of the whole exhaust system shall not exceed the limit specified in the datasheet of the diesel engine.
- Components of the exhaust system shall not apply too much stress on the exhaust manifold or turbocharger due to gravity, inertia, relative movement between components and thermal expansion.
- The exhaust system must be able to prevent splash water, rainwater, flush water or other sources of liquid from entering the diesel engine or turbocharger.
- Make sure the exhaust gas of the diesel engine do not produce any harmful results to the surrounding and operation staff.

Layout and construction of exhaust piping

- Stainless steel corrugated pipes must be used to connect the engine exhaust outlet and the exhaust pipe or as elbow in the exhaust piping. Besides, non-flammable flexible suspension rods hanging from the ceiling or ground elastic supports shall be provided to support the pipes to absorb thermal expansion, genset movement and vibration.
- Each genset must have its own exhaust piping with outlets exposed to the atmosphere. No check valve is allowed in the exhaust piping.
- The exhaust piping shall be as short and horizontal as possible with a minimum total length and number of bends. Each section of pipe shall not be too long or with sharp bends, and shall contain no more than 3 elbows. With regard to the pipe size, for the first 9m of pipes connected to the engine exhaust outlet, the pipe inner diameter shall be the same as that of the engine exhaust outlet; for the next 6m of pipes, the inner diameter shall be increased by 2.54cm; thereafter, the inner diameter shall be increased by 2.54cm for every 9m increase of pipes, until a maximum pipe length of 27m.
- The outlet of exhaust system shall be provided with protections to prevent rainwater from entering the exhaust pipe. For the vertical up outlet, automatic rain cap shall be provided.
- When the exhaust pipes run through flammable roof, wall or other partitions, insulating sleeves and wall boards shall be used for heat insulation. The insulation sleeve shall be of an inner diameter about 25mm larger than the outer diameter of the exhaust pipe, and thermal insulation material shall be filled in the gap between the sleeve and the pipe.
- Try to locate most of the exhaust pipes outside the generator room to reduce heat radiation. All exhaust pipes inside the room shall be insulated with 50mm thick, high density thermal insulation material with aluminum sheathing. The minimum distance between the exhaust pipes and flammable materials is 300mm.
- The exhaust system shall be placed in a high leeward position.

3.6 Connection of Fuel System

The diesel provided for the genset must be clean and free of paraffin wax, water or other corrosive liquid, or too much air. Before being drawn into the daily fuel tank, the diesel must be pretreated in an external high-capacity tank for sedimentation.

- For most simple installation, the fuel tank shall be placed in such a place that the highest fuel level is at most 2.5m above the genset base frame, or a sub/auxiliary tank must be used.
- The fuel tank shall be clean without rust or corrosion. It is usually made of terneplate, phosphate coating plate, reinforced plastic or aluminum sheet. Galvanized sheet is not allowed as it will form flake oxide in contact with the fuel, scale and cause clogging in the fuel filter and injector.
- The oil suction of the fuel injection pump shall be in the center of the tank, 25mm above the tank bottom, to reduce suction resistance and avoid sucking in water and impurities.
- The inlet of the fuel injection pump shall always be positive static pressure head. The outlet of the fuel tank shall be at least 0.5m above the mounting surface of the genset; however, it shall not be too high, to avoid the oil inlet pressure exceeding the withstanding range of the fuel injection pump. In applications with strict requirements on starting performance of the genset, e.g. the gensets work in parallel or quick starting is required in emergency, the fuel tank or reservoir shall be placed in such a position that the lowest fuel level is 150mm higher than the intake of the fuel injection pump, which will prevent air accumulation in the fuel pipe when the genset is on load.
- The connections of the return pipe shall not be positioned too high to exceed the suction of the fuel injection pump, normally below 2.5m.

Fuel pipe

- The fuel pipe connected to the engine shall be made of flexible hose to absorb genset vibration and displacement.
- Black iron pipe shall be used to convey diesel. Cast iron or aluminum pipe joints are forbidden since they have a risk of leakage due to loose structure.
- Do not use galvanized pipe, joint or tank; otherwise, the sulfur in the fuel will combine with the condensate in the tank to form sulfuric acid, corroding the galvanized layer, producing debris and causing clogging in the fuel injection pump and filter.
- Select appropriate pipe size to keep the flow resistance within the permissible range. The fuel pipe size shall be at least the same as the inner diameter of the fuel injection pump inlet. If the fuel tank is far from the engine, increase the pipe size and keep a minimum number of elbows and joints.
- Whether the engine is running or in standby, even the slightest leak is not allowed in the fuel system; otherwise, air may enter the fuel system through the leak and impair the stability and output power of the engine.
- During installation of the fuel system, take necessary measures to prevent the entry of moisture, dust and other pollutants. Clean every component of the fuel system before installation.

3.7 Installation of Cooling And Ventilation System

The cooling and ventilation system is extremely important for the generator room. There must be sufficient air flowing through the generator room to supply engine combustion and cooling. To allow the engine to work at its best, when the genset is running with full load, the temperature rise in the generator room shall be

within 10~15°C above the ambient temperature in the generator room that shall be lower than 40°C. If the ambient temperature in the generator room is higher than 40°C, air supply for the engine must be taken from the atmosphere via duct.

The following three cooling systems are available

- Engine mounted (standard) radiator
- Remote mounted radiator
- Engine mounted heat exchanger

3.7.1 Engine mounted (standard) radiator

The genset is supplied with an engine mounted radiator as standard. The genset must be placed in a room with good ventilation, where the fan draws in air and drive it through the radiator and then discharge it outdoors through the exhaust pipe connected to the radiator. Requirements of this cooling system:

- In the generator rooms with good ventilation, the ventilation area of the hot air exit shall be 1.25 to 1.5 times that of the radiator. If grid or louver is mounted on the hot air exit, make sure the valid ventilation area is sufficient.
- When installing the genset, locate the radiator as close to the hot air exit as possible to prevent hot air recirculation. If no air duct is provided, it is recommended that the distance between the radiator and the hot air exit does not exceed 150mm, or canvas or thin-walled air duct shall be installed. It is also recommended that the distance between the radiator exhaust surface and air barrier is at least 2m, so that the exhausted hot air will not be reflected by the barrier to heat the radiator, resulting in increased temperature of cooling water.
- The air duct shall be of smooth inner surface and free of obstacles, leaks and sharp bends. The change of duct cross-section area shall be gradual, if necessary, be equipped with diversion plates to reduce pressure loss. If the air flow pressure difference is too big and is impossible to change, electric fan may be used for forced air exhaust.
- The air exit shall be located higher than the air intake to allow air to flow through the genset and facilitate air convection, air flow and air suction.
- Fresh air temperature around the radiator shall not exceed the designed environment temperature of the selected radiator (40°C or 50°C), otherwise, proper measures shall be taken to cool down the generator room.
- The system shall be protected from infiltration of rain and snow. In cold regions, heat preservation measures must be applied to the generator rooms where standby or seldom-operated gensets are located, such as air damper which is opened or closed according to the actions of the genset. The air damper can re-guide the exhausted hot air into the generator room to heat the room and improve the working efficiency of the engine.
- In cold regions, for the genset automatically run upon mains failure, the cooling water shall be always treated to increase anti-condensation capacity, which may be an even mixture of cooling water and 40% ~ 60% ethylene glycol. In addition, submerged thermostat-controlled coolant heater (supplied by mains supply) shall be used. When the genset is in standby, the heater shall be able to heat the cooling water automatically according to the environment and cooling water temperature to maintain the cooling water temperature between +5°C and 40°C.
- The cooling system must be equipped with an anti-corrosion water treatment apparatus (water filter). The water filter contains anti-corrosion additive, helping maintain a certain level of chemical concentration in the cooling water and protecting the cooling channel from erosion or corrosion. The

water filter also filters out impurities, dirt and mineral deposits during the continuous circulation of the cooling water, guaranteeing the cleanliness of the cooling system. However, the cleaning interval of the cooling system shall not be more than 30 days or 250 hours.

3.7.2 Remote mounted radiator

When good ventilation is not available in the generator room, a remote mounted radiator system can be adopted; however, considerations must be given to anti-freezing of the ductwork and necessary surplus air supply to support engine combustion and cooling.

- The coolant flow resistance outside the engine (including friction pressure loss of piping, equipment and radiator) and the static head (liquid column height based on the central line of the crank) shall not exceed the specified value in the engine operation instructions.
- Over-high static head (water pressure) will damage the shaft seal of the cooling pump, while over-high drag head (pressure loss) will lead to overheat of the engine. If the friction resistance of the coolant exceeds the specified value, a backup water tank and an electric water pump are required. The backup water tank shall have a capacity over 15% of the total coolant volume of the system. If the remote mounted radiator is over 3m higher than the central line of the genset crank, an auxiliary water tank or a pressure relief valve is required to avoid damage to the shaft seal of the cooling pump.

3.7.3 Engine mounted heat exchanger

The engine, circulating pump, heat exchanger and cooling tower or cooling pond form a closed pressure circulation cooling system. The engine coolant and raw water are circulating in separated pipes. This cooling system requires less space than the remote mounted radiator, but considerations must be also given to anti-freezing of the ductwork and necessary surplus air supply to support engine combustion and cooling.

- There must be enough raw water to absorb the heat from the coolant. The temperature of raw water after the heat exchanger shall not exceed 60°C.
- Full consideration must be given to the feed water pressure of the heat exchanger. If the pressure is higher than the permissible value of the heat exchanger, a pressure relief valve or an auxiliary water tank must be used.
- The cooling system composed of cooling tower and heat exchanger can avoid water pollution, freezing and similar problems.
- When designing the cooling water circulation system, considerations must be given to the necessity of installing filtering devices, such as filter screen or filter. The turbidity of the circulating water shall not be higher than 50mg/L. No oil contaminant or impurities are allowed. The cleaning interval of the cooling system shall not be more than 30 days or 250 hours.
- The selected hot water circulation pump shall match with the cooling tower, of which, the rated flow shall be close to the processing capacity of the cooling tower, and the rated water pressure shall meet the nominal pressure of the nozzle at the water distributor of the cooling tower. If the height difference between the water distributor and the discharge pump of the engine is between 2.5m to 3.5m (please refer to the technical specification of the engine for specific information), it is unnecessary to install circulation pump, instead, connect the water outlet of the engine heat exchanger directly to the water inlet of the cooling tower.

Note: when the remote mounted radiator or heat exchanger is used for the genset, the radiant heat generated by the genset shall also be discharged to the atmosphere.

3.8 Electrical Connection

After the mechanical connection is finished, the users may start the electrical connection according to the supplied drawings. The electrical connection of the genset includes connections of load, electric control line and battery. Only qualified electricians are allowed to carry out electrical connection work and they shall be verified and approved before operation. All connections, cable size and layout must comply with relevant electrical code.

3.8.1 AC circuit

3.8.1.1 Load connection

No matter what kind of connection form is used, triangle or star connection, the phase sequence of the genset and the load shall be the same.

3.8.1.2 Load balance

When connecting the genset to the load, balance the load so that the same magnitude of current flows through every terminal. If the genset is connected to a single-phase load and a three-phase load simultaneously, special attention must be given to load balance. If the current of every phase is approximately the same (within 10% difference) and the line current does not exceed the rated value stated on the nameplate of the genset, the genset can be connected any combination of single-phase and three-phase loads. During operation, check the reading of the ammeter on the control panel to monitor the current flowing through every terminal.

3.8.1.3 Earthing

Earthing means connecting the metal parts and/or the circuits of the generator to the ground. The design and installation of the earthing system are subject to many factors, such as requirements on the earthing fault protection for compound transformer and the actual location of the generator. Please consult qualified electrical engineer when installing the earthing system. Generally, follow the design code of internal combustion genset, that is, the three-phase, four-wire TN-S system with direct earthed neutral point shall be used. The neutral (N) wire shall be separated from the protective earthing (PE) wire in the whole system to work with the gradual creepage protection, to ensure electrical safety. However, when using this system, attentions must be paid to the following problems:

- The protective neutral wire shall never be disconnected;
- Equipment within the same electrical circuit are not allowed to be partially earthed and partially connected to the neutral line;
- Requirements on material and connection of protective neutral wire: the cross section of the PE wire shall be no smaller than that of the working neutral wire and shall use bicolor wires of yellow/green. The protective neutral wire connected to electrical equipment shall be insulated stranded copper wires with a cross section of at least 2.5mm^2 . The protective neutral wire shall be connected securely to electrical equipment with copper lugs, and hinge joint is not allowed. The terminals of the electrical equipment shall be galvanized or applied with anti-corrosion grease. The protective neutral wire shall be connected to the terminal block on the distribution board and no joint is allowed in other positions.
- Requirements on earthing resistant:

>100KVA low voltage genset

$R < 4 \text{ ohm}$

<100KVA low voltage genset	$R < 10 \text{ ohm}$
Protective earthing of electrical equipment	$R < 4 \text{ ohm}$
Re-earthing of neutral wire	$R < 4 \text{ ohm}$
Earthing short-circuit current $I_d > 4000A$	$R < 2000/I_d$
Earthing short-circuit current $I_d < 500A$	$10 \text{ ohm} > R < 120/I_d$

3.8.2 DC circuit

3.8.2.1 DC circuit connection

The control circuit must be laid in a conduit isolated from AC power cable, since the alternate current may sense false signals from the DC circuit and destabilize or even halt the engine, causing interference to the control circuit. The DC circuit must be connected according to the drawings.

3.8.2.2 Battery connection

- The battery shall only be connected after all other processes to avoid accident starting of the genset. Be sure that the negative electrode (-) of the battery be connected at last to reduce the risk of electric arc.
- The starting system is powered by 24V battery current, which is usually provided by two 12V batteries in series. Ensure that the positive and negative electrodes are connected correctly. If the battery is placed far from the genset, increase the starting cable size.
- Do not put any tool or metal objects on, or let them fall onto the top of the battery. Try to use tools with an insulated handle. If the batteries are seldom used (e.g. as emergency backup), they may discharge and fail to start the genset. To solve this problem, the automatic genset from our Company is supplied with a utility power float charger. When disconnecting the battery, the mains supply to the float charger must be cut off before disengaging the charge terminal. When fixing the battery to the genset, connect the earthing terminal at the last, and disconnect it first when removing the battery.

3.9 Noise Reduction Project

We also able to construct noise reduction projects upon request.

Based on relevant analysis, the noise of diesel genset comes from the following sources:

- (1) Aerodynamical noise from the air inlet and air vent of the generator room;
- (2) Machinery noise of the engine and generator;
- (3) Electromagnetic noise;
- (4) Noise produced by vibration and transmitted by the ground.

According to acoustical principles, sound absorption and insulation measures are taken to the ceiling and inner walls of the generator room.

- Light steel keel and gypsum boards are used to form a sound insulating layer on the ceiling of the generator room; beneath this layer, sound-absorbing mineral wool are laid and perforated decorative boards are mounted, to reduce low-frequency sound penetrating into the upper floor and reduce reverberant sound inside the room.
- For the walls, sound-absorbing materials and triangle keel are laid and then perforated decorative boards are mounted, to reduce reverberant and reflected sound during machinery operation.
- Air vent of the exhaust duct is provided on the soundproofing wall. Canvas connection are used between this air vent and the genset radiator to reduce vibration transmission during genset operation and drive

all hot air into the exhaust duct; moreover, noise-reducing grids are installed in the exhaust duct to enable gradual noise attenuation and smooth hot air exhaust.

- Lamellar silencers are installed in the air inlet duct to reduce noise leak.**
- Spring dampers are inserted between the foundation and the genset base frame to lessen vibration impact on the floor. Linear damping spring hooks are used to fix the suspension components of the smoke pipe and corrugated expansion joints are installed in the smoke pipe, so as to reduce the spread of vibration noise through the solid.**

Chapter IV. Testing And Commissioning

※ **Prior to starting, read the supplied technical documents carefully and do all necessary preparation work.**

4.1 Checks And Precautions before Testing

- Check if the genset surface is thoroughly cleaned and if the anchor bolts, flywheel bolts and nuts of other moving parts are tightened properly; if any loose, tighten.
- Check if various clearances meet the corresponding requirements, in particular, the clearance of various intake valves, exhaust valves and pressure relief mechanism.
- Place all cylinders to the decompressed position, rotate the crank and check if there is any abnormal sound while the cylinder parts in motion and if the crank can rotate freely; and then, switch off the pressure relief mechanism and rotate the crank, check for air leak of the cylinders, and if it is difficult to rotate the crank, it means the compression is functioning properly.
- Check the speed governor and overspeed protection to prevent runaway failure.
- Check the fuel supply system:
 - Check if the air vent on the fuel tank cap is blocked and clean any dirt in the vent. Check if the grade of the filled diesel meets the operational requirement of the diesel engine and if the diesel volume is sufficient, and turn on the fuel line switch.
 - Switch on the pressure relief mechanism and rotate the crank, clear injection sound in every cylinder indicates good injection functioning; however, no injection sound and no fuel feed may indicate air in the fuel line, unscrew the bleed screws of the diesel filter and the fuel injection pump to discharge air in the fuel line.
 - Check for oil leak of the fuel pipes and joints, if any, fix it immediately.
- Check the water cooling system:
 - Check if there is enough cooling water in the water tank, if not, add sufficient clean, soft water.
 - Check for water leak of the water pipe joints, if any, fix it immediately.
 - Check if the impeller of the cooling pump rotates smoothly and check the V-belt tension. To check the V-belt tension, press the middle part of the V-belt by hand, if it is pressed down 10~15mm, it means the tension is proper.
- Check the lubrication system:
 - Check for engine oil leak of the oil pipes and joints, if any, fix it immediately.
 - Check the oil level in the oil pan, pull out the dipstick next to the crankcase and check if the oil level meet the specified requirement, if not, add engine oil. If the oil level is higher than the specified level, analyze the causes carefully, with reference to the following:
 - Too much oil;
 - Diesel leaks into the crankcase and dilute the engine oil;
 - Cooling water infiltrates into engine oil.
 - For the oil holes needs manual refilling, fill in engine oil or grease with a grease gun.
- Check the starting system
 - For genset with electric starting system:
 - Check if the specific gravity of the starting battery electrolyte is between 1.240 and 1.280, if the specific gravity is lower than 1.180, it means the battery runs low;

- — Check if the electrical circuit is connected correctly and the control system get prepared to monitor the starting of genset. The air break switch shall be in open position;
- — Make sure the battery terminals are free of dirt or oxidation. If any, rub off the dirt or oxide;
- — Check if the electrical contacts of the starter motor and the solenoid operating mechanism provide good contact.

• For genset with compressed air starting system:

- — Check if all joints of the air pipe on various positions are tight and free of air leak;
- — Ensure the pressure of the air bottle is between 2500 ~ 3000 kPa.

4.2 Commissioning under Rated Conditions

The genset is available in two versions i.e., common and automatic. Please refer to their respective User Manual for the starting methods.

① Starting

- Firstly, adjust the engine to idle speed (500~700rpm). For the engine with mechanical speed governor, use the speed governing lever to adjust the speed. For the engine with electronic speed governor, use the idle knob on the speed controller to adjust the speed.
- Switch on the power supply. For the genset with protection mechanism, start the genset after confirming no alarm signal is given by the alarm lamps.
- For the engine with pre-heating and pre-lubricating mechanisms, start the genset after the pre-heating and pre-lubricating processes are completed. If the genset is not started successfully within 10 seconds, release the Start button immediately and try it again after 2 minutes. If the starting attempt fails for the third time, do not try again. Find out the problem and fix them. Then, the genset may be restarted and the interval between two starting attempt shall not be less than 30 seconds.
- When the genset is successfully started, release the Start button immediately. Now, the charging ammeter shall point to the positive position or the charging voltmeter shall indicate a charging voltage no less than 25V, which means the charger is working properly. For the genset with protection mechanism for working conditions, in case of any light or acoustic alarm, stop the genset immediately and find out the problem.
- After the genset is started, the idle speed shall remain between 500 and 700 rpm. Keep a close watch on all instrument and pay attention to any abnormal noise or phenomenon, if any, decision must be made as whether to stop the genset for a check.

② Running under rated conditions

- After the genset is started successfully, increase the engine speed gradually to the rated speed. If the genset can work well with no load, engage the genset circuit breaker to supply power to the load. If the genset fails to automatically establish voltage, check if the AVR is working properly and magnetize the generator if necessary. When voltage is established, adjust the no-load voltage to the rated voltage via the voltage-tunable resistor, and then engage the genset circuit breaker to supply power to the load.
- If several gensets work in parallel, the operation staff shall ensure the gensets are synchronized correctly before turning on the shunt switch, so as to avoid impact of asynchronous paralleling on the gensets.
- If the paralleling attempt fails for several time, remove the load promptly, separate the gensets and adjust each genset individually.
- During normal operation of the genset, carry out real-time check on the working conditions of each part. Pay attention to the instruments and alarm lamps, and record the readings every hour. Usually, the

cooling water temperature is 90°C and shall not exceed 95°C.

- Check the fuel level and engine oil level of the engine regularly. Refill when the fuel level goes below 1/3 of the fuel tank. Add engine oil when the oil level on the dipstick is below the lowest mark.
- Load variation shall be gradual and even. Except in special conditions, sudden engagement and disengagement of loads are not allowed. The genset shall not work at full load before the water after the radiator reaches 55°C and the engine oil reaches 45°C.
- For the genset located in a noise-proofing room, regularly go into the room and check the working conditions of the genset, and record the instrument readings. If any abnormality is found, solve them promptly.
- During the operation of the genset, dedicated personnel is required to check and replace the air, diesel and oil filters. If any leakage of air, fuel, oil or water is found, fix them promptly.

③ Shutdown

- Reduce the load gradually until completely remove it from the genset. Disengage the genset circuit breaker and let the engine run at idle speed for about 3 minutes before shut it down. Avoid emergency shutdown when the engine is running at full load to prevent overheating.
- For open-circuit cooling system, shut off the water inlet. In cold environment where the ambient temperature drops below 0°C, the remaining cooling water in the cooling system shall be thoroughly drained to prevent the machine parts from freezing. But cooling water with anti-freezing additive is an exception.
- Standby genset or genset seldom used shall be sealed with grease as required. If no, they must be started to run under load for 5 to 10 minutes at least once per week to avoid rusting of internal parts.
- The emergency shutdown shall be carried out in the following manner: disengage the genset circuit breaker quickly and place the throttle to the Stop position to shut off fuel supply after the load is removed. This will completely shut down the genset.
- After the genset stops running, check the genset in time, wipe off any grease on the genset surface, record the time it stops, check the battery conditions and make the genset ready for the next start.

Chapter V. Running In

5.1 Principles

Before putting a new genset into operation, proper running in must be conducted according to the User Manual of the diesel engine to smoothen the surface of moving parts and prolong the engine life. For old gensets that haven't been used for a long time, running in is also required before restarting. When running in the genset, to ensure good running-in results, the load and the engine speed shall be increased on a gradual basis, and the consistency of engine oil shall be increased gradually. In the course of running in, avoid operating the genset with no/low load for long period. Or it may lead to the following results: increased engine oil consumption, engine oil/diesel leaks from the exhaust pipe, carbon deposits on the piston and piston ring groove, incomplete combustion and engine oil dilution. Therefore, the genset is not allowed to run with low load for more than 10 minutes. The standby genset must run with full load for at least 4 hours every year to burn off the carbon deposits in the engine and exhaust system, so that the carbon deposits will not impair the life and quality of moving parts of the diesel engine.

5.2 Steps of Running In

- Run the genset at no load. Check the genset thoroughly as per methods aforementioned. When all parts function properly, start the genset. Adjust the engine speed to idle speed and let it run for 10 minutes. Check the oil pressure and listen to the running sound of the engine. Stop the engine.
- Open the side cover of the cylinder block and check the temperature of the main bearing and the connecting rod bearing with hand, which shall be no higher than 80°C or such as your hand would get burnt. Monitor the conditions of all working parts. If all parts are in good conditions and have appropriate temperature, proceed with the following step.
- Raise the engine speed from idle to rated speed gradually in increments of 200r/min, let the engine run continuously for 2 minutes at each steep level; nevertheless, the total time for the engine running at no load shall not exceed 5-10 minutes. During running in, the cooling water temperature shall always maintain at between 75-80°C and the engine oil temperature shall be no higher than 90°C.
- Connect the genset to the load if everything is ok with the genset and the load is in conformity with the technical requirements. When the genset runs at rated speed, increase the load in a step-by-step manner: first maintain the load at 25% rated load, then raise it to 50% and then 80%. During running in, check the engine oil level, replace lubricant, clean the oil pan and the oil filter every 4 hours.
- Check if the main bearing nuts, connecting rod bearing nuts, cylinder head nuts and fuel injection pump and injector screws are tightened securely. Ensure the valve clearance is correct, and adjust it if necessary.

5.3 Expected Performance after Running In

- The genset can be started quickly without fault;
- The genset runs at rated load stably and smoothly with no abnormal noise;
- In rapid changes of load, the diesel engine can return to a stable speed as soon as possible. When running at a high velocity, the engine doesn't get runaway, neither does the speed fluctuate. When running at a low velocity, the engine doesn't get flameout or misfired. The transition from one load to another is smooth, and the color of exhaust smoke of the engine is normal;
- The temperature of the cooling water and all lubricated parts is normal and the engine oil pressure is within the expected level;
- The genset is free from fuel / oil, water, air or current leakage.

Chapter VI. Maintenance during Normal Operation

During normal operation of the genset, watch over the engine, generator and control panel, make a record of the operating status at regular time, pay attention to any change in the readings of output voltage, current, frequency, power and relevant instrument of the engine working status, and accurately record the relevant data in the *Daily Operation Report of Genset*.

6.1 Daily Operation Report of Genset

Date	Time	Line-to-line voltage V			Phase current A			Frequency HZ	Water / oil temperature °C	Engine oil pressure Bar	Battery voltage V	Running time Hr	Color of exhaust smoke	Running sound	Operator	Remark: (problem and troubleshooting)	
		UA	UB	UC	L1	L2	L3										

Note:

- Current for every phase of the load \leq _____ A;
- Mixed use of different types of engine oils is not allowed;
- Check the cooling water level and engine oil level before starting, keep the genset clean;
- After stopping, check for any air, water, fuel or oil leakage of the genset, and any loose fastener. Ensure the power supply is cut off.

- Carry out the maintenance and service work during the daily operation according to the operation and maintenance instructions of the engine, generator and control panel, keep a record properly for future reference;
- During operation of the genset, keep a close watch on the heating, vibration and noise change of all parts of the genset, and pay attention to any air, fuel or oil, or water leakage; in case of any abnormality, check and fix the problem immediately.

Chapter VII. Service

Proper maintenance and service, particularly preventive maintenance, are vital to prolonging the genset life and lowering the operation cost.

7.1 Guidelines for Service

- The daily maintenance work on the genset shall be carried out with reference to the maintenance & service schedule provided by us.
- The service work on the engine and generator shall be done according to the maintenance & service requirements in their respective User Manuals.
- The maintenance & service interval shall be adjusted based on the specific purpose of use and working environment of the genset.

7.2 Maintenance & Service Schedule

Daily service

- Check the instrument panel
- Check the coolant level of the cooling system
- Check the maintenance indicator of the engine air filter and clean if necessary
- Check the engine oil level
- Drain off the water and deposits in the fuel tank and oil-water separator
- Check the functioning of the coolant heater
- Check the engine

Service after the first 250 hours of operation

- Check the engine valve clearance and adjust if necessary
- Clean and test the magnetic speed sensor
- Replace the lubricant and filter
- Replace the coolant filter
- Clean and / or replace the fuel filter

Service for every week or every 50 hours of operation

- Check the air filter
- Drain off the water in the oil-water separator
- Check the level of the battery electrolyte
- Check the engine oil level
- Check the coolant level
- Check the engine exhaust piping
- Check the fuel supply system
- Check the electrical connection
- Check the sensors and alarm output to ensure their reliability

Service for every month or every 100 hours of operation

- Check the air intake and exhaust systems to ensure they are not obstructed
- Check for any leakage of the engine exhaust system
- Check the tension of the V-belt
- Check voltage and electrolyte specific gravity of the battery
- Check the battery charger
- Check the reliable functioning of the ATS transfer switch
- Check the output voltage and frequency of the generator
- Drain off the condensate water in the engine exhaust system
- Drain off the water in the oil-water separator
- Test the load-carrying capacity of the genset

Service for every 250 hours of operation

- Add anti-corrosion additive into the cooling system
- Lubricate the drive bearing of the fan
- Check the hose and fasteners of the engine radiator
- Clean the radiator
- Replace the lubricant and filter
- Replace the coolant filter
- Clean and / or replace the fuel filter

Service for every 6 months or every 500 hours of operation

- Replace the air filter
- Check the anti-freezing fluid
- Check the tension of the V-belt
- Check the insulation and fire-proofing devices
- Check the electric circuit
- Check the tightness of bolts, screws and parts subject to vibration
- Check and adjust the engine valve clearance
- Check and adjust the injection advance angle
- Drain away the deposits in the main fuel tank
- Clean the battery terminals
- Clean the rotor and stator of the generator with compressed air

Service for every year or every 1000~2000 hours of operation

- Replace the coolant
- Replace the oil-water separator
- Replace the engine oil and oil filter
- Replace the fuel filter
- Clean the vent of the engine crankcase
- Adjust and tighten any loose parts
- Check and adjust the valve clearance

- Check and adjust the injection advance angle
- Check the turbocharger
- Check the fuel injection pump and water pump
- Check the transmission mechanism and corresponding phase
- Check the genset protections
- Check and adjust the magnetic speed sensor
- Check the winding and electrical connection
- Measure the insulation resistance

Service for every 2 years or every 2000~3000 hours of operation

- Check the crankshaft vibration damper
- Replace the coolant and clean the cooling system
- Conduct the load-carrying capability test

Chapter VIII. Troubleshooting

8.1 Diesel Engine

Problem	Fault characteristic & possible cause	Troubleshooting
Diesel engine can not start.	<ul style="list-style-type: none"> □ Fuel system fault: 	
	<ul style="list-style-type: none"> · The diesel engine can not be ignited after being driven by the starter motor. 	No return fuel in the return pipe
	<ul style="list-style-type: none"> · Air in the fuel system. 	Check if the fuel pipe joints are loose, and remove the air in the fuel system. First unscrew the bleed screw on the fuel injection pump and fuel filter; pump the fuel with the hand pump, until there is no air bubbles in the overflowing fuel; tighten the bleed screw, continue pumping; when fuel flows into the return pipe, tighten the hand pump.
	<ul style="list-style-type: none"> · Clogged fuel pipe 	Check and ensure the fuel pipes are not clogged.
	<ul style="list-style-type: none"> · Clogged fuel filter 	Clean the fuel filter or replace the filter element.
	<ul style="list-style-type: none"> · The fuel pump does not work or fails while working 	Check the fuel inlet pipe and fuel pump.
	<ul style="list-style-type: none"> · Insufficient or no fuel injection, or non-atomized fuel 	Replace the injector matching parts.
	<ul style="list-style-type: none"> · Speed governing lever of fuel injection pump placed in a wrong position 	When starting the engine, place the speed governing lever in such a position that the engine rotates at 600~800rpm with no load.
	<ul style="list-style-type: none"> □ Electric starting system fault: 	
	<ul style="list-style-type: none"> · Wrong or loose connection of electrical circuit 	Check and ensure the electrical connections are correct and secure.
	<ul style="list-style-type: none"> · Low battery power 	Charge the battery or use more batteries in parallel.
	<ul style="list-style-type: none"> □ The rack bar of fuel injection pump gets jammed. 	Open the sight hole on the high pressure pump, move the rack bar to see if it can move freely. For the high pressure pump with electronic speed governing mechanism, after eliminating the jammed rack bar, short the 1# and 6# terminals on the speed governing plate, now the actuator is in the maximum fuel amount position.
	<ul style="list-style-type: none"> □ Fault of electronic speed governor 	Please follow the testing procedure of the speed governing system (actuator, speed governing plate, speed sensor) specified in the operation instructions of the electronic speed governor and find out the reason.
	<ul style="list-style-type: none"> □ Too early or too late of injection advance angle, or even with a 180° difference; the engine can not be ignited or is extinguished shortly after ignition. 	Check if the reticles on the splice tray of the fuel pump drive shaft are correct and secure, adjust if necessary.
<ul style="list-style-type: none"> □ Wrong valve timing 	Recheck the valve timing.	
<ul style="list-style-type: none"> □ The engine can not be ignited after long starting time due to too low ambient temperature. 	According to the actual ambient temperature, use appropriate auxiliary starting devices.	
Inadequate output power of diesel engine	<ul style="list-style-type: none"> □ Fuel system fault: can not increase speed and output power even when the throttle is increased. 	
	<ul style="list-style-type: none"> · Air in or clogging of fuel pipe or fuel filter 	Drain off the air or replace the fuel filter element.
	<ul style="list-style-type: none"> · Non-atomized fuel supplied by fuel injection pump 	Check, repair or replace the matching parts.
	<ul style="list-style-type: none"> · Inadequate atomization of fuel or low injection pressure 	Check atomizing process or adjust the injection pressure; check if the injector matching parts shall be

		replaced.
	<input type="checkbox"/> Fault of air intake and exhaust system: the exhaust smoke has a higher temperature and worse color than normal.	
	<ul style="list-style-type: none"> ·Clogged air filter 	<p>Wash the air filter element or wipe off the dust on it, replace it if necessary. Also check the engine oil level.</p>
	<ul style="list-style-type: none"> ·Clogged exhaust pipes, too long pipe joint, or small bending radius and sharp bend of elbows 	<p>Clean the carbon deposits in the exhaust pipes, reinstall the exhaust pipes, reduce the number of elbows and increase the bending radius of elbows.</p>
	<input type="checkbox"/> Overheated engine block, too high ambient temperature, too high engine oil and cooling water temperature, too high exhaust temperature	<p>Check the cooler and radiator, remove water scale; check relevant piping and ensure the pipe size is big enough; if the ambient temperature is too high, improve room ventilation to improve cooling effects.</p>

Problem	Fault characteristic & possible cause	Troubleshooting
Abnormal sounds when the diesel engine is running	<input type="checkbox"/> Worn drive gear, enlarged gear clearance: abnormal sounds from the front cover; clash noises heard when the engine suddenly slows down.	Adjust the gear clearance, replace the gear if it is worn out.
	<input type="checkbox"/> No engine oil between the adjusting screw of rocker arm and the spherical seating of pushrod: squeaks of dry friction heard from the cylinder head.	Remove the cylinder head cover and add engine oil.
	<input type="checkbox"/> Too big intake & exhaust valve clearance: big, rhythmic noises heard from the cylinder head.	Adjust the valve clearance.
Abnormal exhaust smoke color	<input type="checkbox"/> Black smoke:	
	·Overloaded engine	Reduce the load to the rated level.
	·Uneven fuel supply among the cylinders	Adjust the fuel injection pump.
	·Clogged air filter, blocked air intake	Remove and clean the air filter
	·Inappropriate valve clearance and / or poor valve sealing	Adjust the valve clearance, check the conical sealing surface and remove any defect.
	<input type="checkbox"/> White smoke:	
	·Inadequate atomization of fuel, with fuel drops	Check the injector matching parts, regrind or replace; adjust the injection pressure to the rated level.
	·Incomplete combustion in individual cylinder when the engine is just started	Increase the engine speed and load properly and let the engine run for a prolonged period.
	<input type="checkbox"/> Blue smoke:	
	·The piston ring gets stuck or worn out, reduced flexibility	Remove and check the piston ring, replace it if necessary.
·The engine constantly runs with low load (below 40% of rated output); enlarged clearance between piston and cylinder liner, causing engine oil to intrude into the combustion chamber.	Increase the load appropriately.	
·Excess engine oil in the oil pan	Reduce the engine oil until its level drops down to the specified level; fill engine oil according to the markings on the dipstick.	
Abnormal engine oil pressure	<input type="checkbox"/> The engine oil pressure drops and can not be restored with the pressure regulating valve, and pressure fluctuation is observed from the pressure gauge.	
	·Oil pipe leakage	Check and repair, tighten the nuts.
	·Air in the engine oil pump, inadequate engine oil in the oil pan	Add engine oil to the rated level or replace the engine oil.
	·Worn crankshaft thrust bearing, poor sealing of oil seal on the flanged end of the crankshaft	Check all these parts and replace any if it is worn out.
	·Rupture of connecting oil pipe between rocker shafts	Check, repair or replace.
	·Engine oil cooler or filter clogged, rupture of cooler oil pipe, oil leakage on seal gasket or gasket damaged	Clean, weld or replace the filter element in time. Aluminum scraps in the centrifugal oil filter mean that the alloy layer on the connecting rod bush is ripped off, check the bush and replace it if necessary; check and replace the seal gasket in time
	<input type="checkbox"/> No pressure of engine oil, pointer of pressure gauge does not move	
	·Oil pressure gauge damaged	Replace.
	·Oil line clogged	Check, repair and clean.
	·Oil pump severely damaged or choked because of improper installation · Failed pressure regulating valve of engine oil pressure, damaged spring	Check and repair, adjust the clearance, test the oil pump performance. Replace the spring, grind the sealing surface of the pressure regulating valve.

Problem	Fault characteristic & possible cause	Troubleshooting
Too high engine oil temperature & too high oil consumption	<input type="checkbox"/> The reading on the oil temperature gauge exceeds the rated value and remains high even after enhanced cooling, while black smoke is seen from the exhaust pipe:	
	·Overloaded diesel engine	Reduce the load.
	·Clogged engine oil cooler or radiator	Clean the cooler or the radiator pipes
	·Inadequate cooling water or wind flow from the fan	Ensure the cooling water flows unobstructed, adjust the tension of the V-belt so that the water pump and fan can reach the rated speed.
	·Inadequate engine oil	Fill engine oil to the rated level.
	·Temperature gauge doesn't work properly.	Calibrate or replace
	<input type="checkbox"/> The oil level in the oil pan drops quickly, the oil color is dark, white smoke is seen from the oil filler on the vent pipe and blue smoke is seen from the exhaust pipe:	
	·Engine oil of inappropriate grade is used.	Choose the right grade of engine oil as specified.
	·The piston ring gets stuck or worn out; the cylinder liner gets worn out.	Replace the piston ring, replace the cylinder liner if necessary.
	·Clogged oil return hole of the piston oil ring due to carbon deposits	Clear off carbon deposits or replace the oil ring.
	·Elastic sealing of the turbocharger fails.	Remove the elastic sealing and check for sintering or elastic failure, replace if necessary.
	·Engine constantly runs with low load.	Increase the load appropriately.
Raised oil level in oil pan	Cooling water infiltration into engine oil, yellow bubbles on engine oil, water vapor condenses on the surface of vent pipe filter element	
	<input type="checkbox"/> Damaged water seal ring of cylinder liner, resulting in water leakage	Replace the water seal ring.
	<input type="checkbox"/> Damaged cylinder head gasket, resulting in water leakage	Replace the gasket.
	<input type="checkbox"/> For water-cooled engine oil cooler, the cooler element is damaged, resulting in mixture of cooling water and engine oil.	Check the cooler element, repair or replace.
	<input type="checkbox"/> Cooling water from the fresh water pump infiltrates into the oil pan.	
	·Water leakage on the fresh water pump shaft and seal gasket	Check the water seal ring, repair or replace; rub the sealing surface.
	·Damaged rubber seal ring of fresh water pump	
Too high water temperature	<input type="checkbox"/> Air in the water pipe: after the engine starts, no or little water flows through the outlet pipe, resulting in rising water temperature.	Unfasten the joints on the water pipe, drain off the air until water flows unobstructed, and then fasten all joints on the water pipe.
	<input type="checkbox"/> Inadequate circulating water; under high load, outlet water and the engine oil would become very hot.	
	·The fresh water pump or fan doesn't rotate fast enough.	Adjust the tension of V-belt to the specified level.
	·Damaged impeller of fresh water pump	Replace.
	·Too wide clearance between the impeller and pump case	Adjust the clearance to the specified level.
	·In open-circuit system, the water supply level is so low that the fresh water pump can not suck up the water.	Raise the water supply level.
	·In closed-circuit system, there is inadequate water in the radiator.	Add cooling water.
	·Clogged water pipes	Clean the pipes, clear off dirt in the cooling pipes.

	□ In closed-circuit system, the radiator surface is covered with dirt, affecting heat emission.	Clear off dirt and clean the radiator surface.
	□ The thermostat doesn't work.	Replace.
	□ The water temperature gauge doesn't work properly.	Repair or replace.
	□ Cracks on the shoulder of cylinder liner: air bubbles in cooling water in the radiator	Replace the cylinder liner.

Problem	Fault characteristic & possible cause	Troubleshooting
Too low water temperature	□ The thermostat doesn't open or close properly or gets damaged.	Replace.
	□ Low ambient temperature, low load	Increase the load appropriately.
	□ The water temperature gauge doesn't work properly.	Calibrate or replace.
Oil in cooling water	Damaged element of water-cooled engine oil cooler	Repair or replace.
	Damaged cylinder head gasket	
Electric starting system	□ The starter motor doesn't work:	
	·Poor contact at electrical connections.	Clean and tighten the electrical connections.
	·Poor contact at brush.	Clean the commutator surface or replace the brush.
	·Short circuit of starter motor	Find out the short circuit part and repair.
	·Inadequate charging or too small capacity of battery	Charge the battery or use more batteries in parallel; or replace the battery if necessary.
	·Poor contact at electromagnetic switch contacts	Check the contacts and burnish them with abrasive cloth
	□ The starter motor gear gets choked with the flywheel ring gear, or the starter motor gear can't be disengaged:	
	·The starter motor is not parallel to the flywheel ring gear center.	Reinstall the starter motor and align it with the flywheel ring gear center.
	·Sintered contacts of electromagnetic switch	Check the contacts, fire away, abrade and singe the rough parts.
	□ The starter motor continues running after the Start button is released:	
	·The moving contacts of electromagnetic switch get sintered with the connecting screw.	Check and repair.
	·The adjusting screw of the starter motor is not adjusted properly.	Readjust.
	□ Abnormal noises from the generator	
	·Loose or broken bearing	Replace the bearing.
	·Collision between rotor and stator	Rub off the collision surface with a file.
	□ The battery can't be charged or provide high current while the voltage drops sharply, with white lead sulfate crystals on the polar plates.	Repair or replace the battery.
□ When charging, the battery features high temperature, low voltage, low electrolyte specific gravity; bubbles are too small towards the end of charging or come out too late; short circuit in the battery	If short circuit is caused by excessive deposits at the battery bottom, discharge the battery completely, pour out the electrolyte, rinse the battery repeatedly with distilled water and recharge it. If it is caused by other reasons, dismantle the battery, replace the separators or polar plates, or have them repaired.	

8.2 AC Generator

Problem	Troubleshooting	Result	Check / cause
Without floating voltage when started	Connect terminals E+ and E- to a new 4-12V battery, keep it for 2-3 seconds, and pay attention to the polarities.	When the battery is removed, the voltage reaches the rated level.	Loss of magnetic field
		When the battery is removed, the voltage doesn't reach the rated level.	<input type="checkbox"/> Check the connection of AVR signal wire. <input type="checkbox"/> Diode failure <input type="checkbox"/> Short circuit of excitation armature
		When the battery is removed, the voltage is established.	<input type="checkbox"/> AVR failure <input type="checkbox"/> Open circuit of exciter field winding (check the winding) <input type="checkbox"/> Open circuit of main motor winding (check the resistance)
Too low voltage	Check the speed.	When the speed is correct,	<input type="checkbox"/> Check the AVR wiring (AVR might have failed) <input type="checkbox"/> Short circuit of field winding <input type="checkbox"/> Burnt rotating diode <input type="checkbox"/> Open circuit of main motor winding (check the resistance)
		When the speed is too low,	Increase the speed (do not adjust the AVR voltage potentiometer before the speed reaches the rated level).
Too high voltage	Adjust the AVR voltage potentiometer	If the adjustment fails,	It means AVR failure.
Voltage oscillation	Adjust the AVR steady-state potentiometer	If the adjustment fails, try normal / fast mode (ST2).	<input type="checkbox"/> Check the speed: it might by aperiodic oscillation.
			<input type="checkbox"/> Loose connection
			<input type="checkbox"/> AVR failure <input type="checkbox"/> The engine speed is too low at loads or the LAN setting is too high.
The voltage is correct at no load but too low at load.	When running at no load, check the voltage between terminals E+ and E- on AVR.	DC voltage between E+ and E-SHUNT/PMG < 10V	Check the speed (or the LAN setting is too high).
		DC voltage between E+ and E-SHUNT/PMG > 15V	<input type="checkbox"/> Rotating diode failure
			<input type="checkbox"/> Short circuit of main rotor, check the resistance. <input type="checkbox"/> Exciter armature failure, check the resistance.
Loss of voltage during operation	Check the AVR, varistor and rotating diode, and replace any failed components.	The voltage doesn't return to the rated level.	<input type="checkbox"/> Open circuit of exciter field winding

Appendix A: Technical Specifications of Fuel, Lubricant & Cooling System

To a large extent, the lifespan, operation reliability and performance of the engine depend on the fuel and lubricant it uses. Therefore, choosing the right fuel and lubricant is critical. Users shall make choice according to the *User Manual of Engine* and strictly stick to it.

Fuel

Light diesel in compliance with Standard GB252-87

In summer: 0#

In winter: -10#~35#

Lubricant

The class 40CD diesel engine oil is recommended for diesel genset, and if possible, the 15W/40CD or 15W/40CC diesel engine oil can be used. In case of lack of 40CD diesel engine oil, the users may choose other engine oils instead with the same quality and similar performance. However, never mix different engine oils for use.

Cooling System

Cooling water

Clean alkaline water which does not contain corrosive compound, e.g. chloride, sulfate or acid, can be used as cooling water. Its main requirements include:

Hardness	0.7~5.3 me/L
Chloride ion content	< 150mg/L
PH value	6~8.5

CAUTION:

DO NOT use well water, seawater or spring water directly as cooling water. These hard waters contain lots of mineral substances that generate scale easily which chokes the pipelines, and as a result, the cooling effect is reduced, and the engine may become overheated or generate less power. In addition, the seawater is highly corrosive and can easily destroy internal parts of the engine. The excessively hard waters must be softened before being used for cooling. However, if the water is too soft, air bubbles are apt to form and may also corrode the cooling parts severely. Thus, DO NOT use distilled water or rainwater directly as cooling water.

Additive

To reduce or avoid corrosion of cooling parts, mineral deposit, cavitation of cylinder liner and frothing of coolant, some rust-preventive emulsion or cooling water treatment agent made of anti-corrosive oil should be added into the cooling water.

CAUTION:

The concentration of the added additive must be appropriate. High concentration may result in the additive separating from the cooling solution and the forming of gel on the radiator or heat exchanger, and deposit may also form on the pump seal ring to lead to the leakage of seal ring. However, the cooling effect is reduced if the concentration is too low.

The rust-preventive emulsion can be made of NL anti-corrosive oil according to the quality of the water used. In general, the following methods can be followed:

- Heat, settle and soften clean water, and then add 0.4%~0.6% (percentage of weight) of NL anti-corrosive oil into the water and mix thoroughly.
- Soften water by using a sodium ion exchanger, and then add 0.3%~0.4% (percentage of weight) of NL anti-corrosive oil into the water, and heat and mix thoroughly.

If the diesel engine uses the rust-preventive emulsion for the first time, a coat of oil film will attach to the internal surface of metal, and thus the content of anti-corrosive oil should reach the upper limit. The rust-preventive emulsion can prevent rust and corrosion, and should be used continuously for a new engine from the beginning. If a diesel engine is used after the scale has already formed inside it, air bubbles are apt to form due to the chemical reaction and the cooling effect is reduced.

Anti-freeze solution

The anti-freeze solution included in the cooling fluid can prevent boiling or freezing, avoid cavitation of water pump and also reduce cavitation of cylinder liner. In case a closed-circuit cooling system is employed, the anti-freeze solution should be used in cold seasons. The normal anti-freeze solution can be divided into two types: glycerin-water solution and glycol-water solution.

CAUTION:

Glycol is toxic. Protection measures must be taken to prevent intoxication during the keeping, making and use of it.

Glycol is highly water-absorptive, and should be stored in a sealed container to prevent any leakage to cause any loss after it absorbs water.

Glycol-water solution loses evaporated water when being used, and thus water should be added.

The used anti-freeze solution should be well recycled and kept. After settlement and filtering, add water into it to adjust the concentration. It can be used again for 3~5 years in general. When using the anti-freeze solution, choose a freezing point that is 5°C lower than the lowest temperature of the area where it is used. Firstly make the solution according to the composition proportion with the highest freezing point, and then add glycerin or glycol step by step.

Users may also choose to use the anti-freeze solution made by the manufacturer and the cooling fluid that prevents rust, scale and freezing.

Appendix B: Storage, Testing & Maintenance of Lead-Acid Battery

Please read the User Manual of the battery first.

Battery is an essential part of any backup generator system, and 90% of generator failures stem from battery.

- Storage:** The batteries should be stored in a cool and dry place where they should not be piled up one by one and should be placed on wooden pallets or proper thick cardboards to protect the floor.
- Testing**

Pre-test procedure

•Check the batteries and their terminals for any physical damage and make sure they are in a clean and dry condition.

•Apply petroleum grease on the terminals to prevent corrosion.

•Test whether the voltage is higher than 12.3V. If not, charge the battery for 5-6 hours before use, with a current equivalent to 1/10 of the Ampere-hour rating.

•Make sure of the correct polarity of the terminals during the installation.

•The batteries generate combustible gas (hydrogen) while being charged, so its vent cap and any seal must be opened; otherwise, the polar plates or separators would be damaged. The batteries should stay clear of any objects on fire. The vent of the water hole cap should be poked through with a needle.

Charging

Maintenance-free battery:

Maintenance-free batteries have already been charged and had fluid inside before sent out of the factory. They can be directly connected into the genset and charged by the charger of the genset. The bolt of each wiring terminal should be tightened before use, to avoid sparks or poor connection. Under the normal charging voltage, the electrolyte only generates few gas, and the polar plates are highly capable of resisting over-charging. The battery is good when starting up at a low temperature, and no distilled water should be added throughout the whole period of use. However, the specific gravity of the electrolyte should be inspected during the maintenance.

Dry-charged lead-acid battery

•To ensure that the electrolyte is mixed thoroughly inside the battery, the battery should be charged for at least 5 hours with a current equivalent to 10% of the Ampere-hour rating. It should be longer if the battery has been set aside for a period of time.

•The specific gravity of the electrolyte after the first charging should reach 1.28~1.3 (15°C). If it is not in this range, use distilled water or diluted sulfuric acid with a specific gravity of 1.4 to adjust.

•To guarantee that the battery is well charged, the charging should be continued for 1 hour after the adjustment. In case the temperature of the electrolyte is approaching 43°C (or 49°C for tropical climate) or the battery voltage reaches 15V, the charging speed and charging current should be reduced until the electrolyte temperature lowers, so as to avoid damaging the polar plates as a result of the overheated electrolyte.

CAUTION: The charging time should be extended in the following cases.

•If the battery has been stored under an ambient temperature of above 30°C and a humidity of above 80% for 3 months or longer, the charging time should be extended to 8 hours.

•If the battery has been stored for 12 months or longer, the charging time should be extended to 12 hours.

•After the charging process is ended, check the level of electrolyte. Add more electrolyte with correct specific gravity if needed, and then put the vent cap back into its position.

•Use an electric gauge to check the output of the AC charger while the genset is running.

Maintenance

Storage

•Keep the batteries and the surrounding area clean, dry and free of filth. Especially the surrounding area of the air plug should be kept clean.

•Keep the uncharged and charged batteries in a cool, dry and well-vented place.

•Make sure the vent cap or plug is tightened.

•Keep the terminals and connectors free of corrosion and apply petroleum grease on them.

•Check the electrolyte level, and add distilled water or deionized water to maintain at a correct level

Charging

If the genset is used once for a while, the specific gravity of battery electrolyte will decline; so the batteries must be charged until the specific gravity of all units rises and becomes stable within 3 hours. If the genset is seldom used, the batteries must be charged every month to keep them in a startup-ready status. For batteries that are normally charged, a deep charging should be conducted every 6 months until both voltage and specific gravity rise.

Appendix C: Use of Genset under Harsh Conditions

Environmental Factor

In plateau regions of high altitude

The engine of genset, especially the naturally aspirated engine, loses some power when used in plateau regions where the fuel in the thin air can not be burned as much as at the sea level. For naturally aspirated engine, 3% of its power is lost for each rise of 300m altitude. So lower powers should be chosen in plateau regions to avoid smoking and high fuel consumption.

Under extreme cold climate

•Add an auxiliary starting device (fuel heater, engine oil heater, jacket heater, etc.)

Use the fuel heater or electric heater to heat the cooling water, fuel and lubricant to warm the engine up, so it can start up successfully.

If the temperature of the machine room is not lower than 4°C, install a jacket heater to keep the temperature of the engine cylinder at over 32°C.

In an environment where the temperature may decline to below -18°C, the genset also needs lubricant heater, fuel pipe heater and fuel filter heater to prevent the fuel from freezing. Installed on the engine oil pan, the engine oil heater heats the engine oil inside the oil pan to start the diesel engine under a low temperature.

-10#~-35# light diesels are recommended.

•Heat with an intake air pre-heater

Use an intake air pre-heater (electric pre-heating or fire pre-heating) to heat the gas mixture (or air) entering into the cylinder, so as to raise the compression end temperature and improve the firing condition.

The electric pre-heating is a method that heat the intake air with a glow plug or heating wire mounted inside the intake pipe. It does not consume the oxygen in the air, neither does it pollute the air, but it consume the electric energy of the batteries.

•Use low-temperature lubricant

Use low-temperature lubricant with lower viscosity to increase the fluidity of lubricant and reduce the internal frictional resistance of the fluid.

Use high-energy battery

Use high-energy battery, e.g. the Ni-MH battery, Ni-Cd battery, etc. Special attention should be paid to the heating or insulation of the battery. A battery heater may be needed if the temperature of the machine room may decline to below 0°C, in order to maintain the capacity and output power of the battery.

•In an environment with high humidity, the winding and control box of the genset should be provided with a heater, to avoid short circuit or broken insulation in the winding and control box as a result of condensation.

CAUTION:

For engines of different purposes and models, different startup methods should be employed, as they require different startup conditions. Multiple methods may be taken at the same time for engines that require high startup conditions, to make sure they starts up under a low temperature.

Install a glow plug
Use some primer fluid
Increase concentration of gas mixture
Ether auxiliary starting

In a filthy condition

Parts may get damaged if the genset is running in a filthy and dusty environment for a long period. The buildup of filth, dirt and dust may wrap the parts, making the maintenance more difficult. The buildup may include corrosive compounds and salts which may damage the parts. Therefore, the maintenance cycle must be shortened to maximize the lifespan of the machine.

Comparison between several typical air inlet sample

Suggested

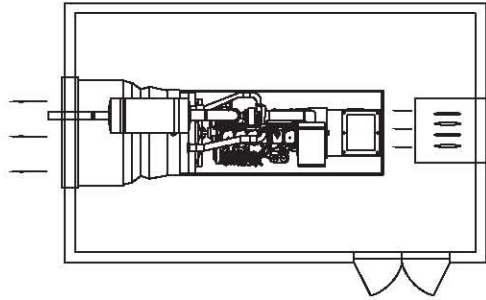

Suggested

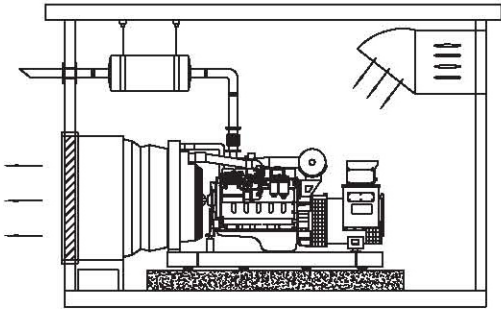

Suggested

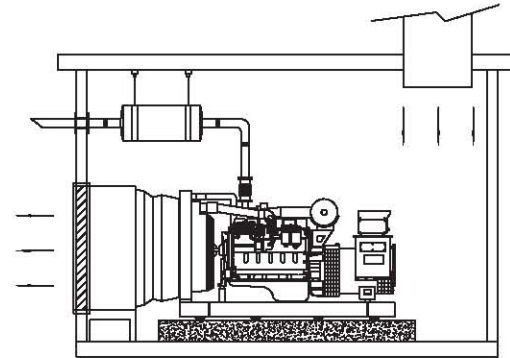

Non-suggested

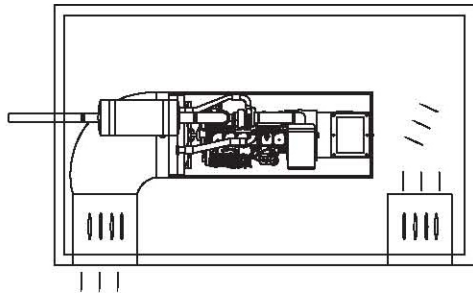

Non-suggested

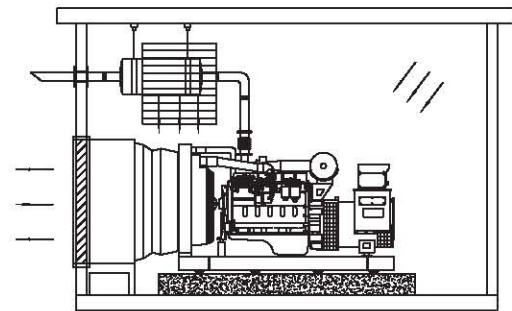

Remote radiator system drawing

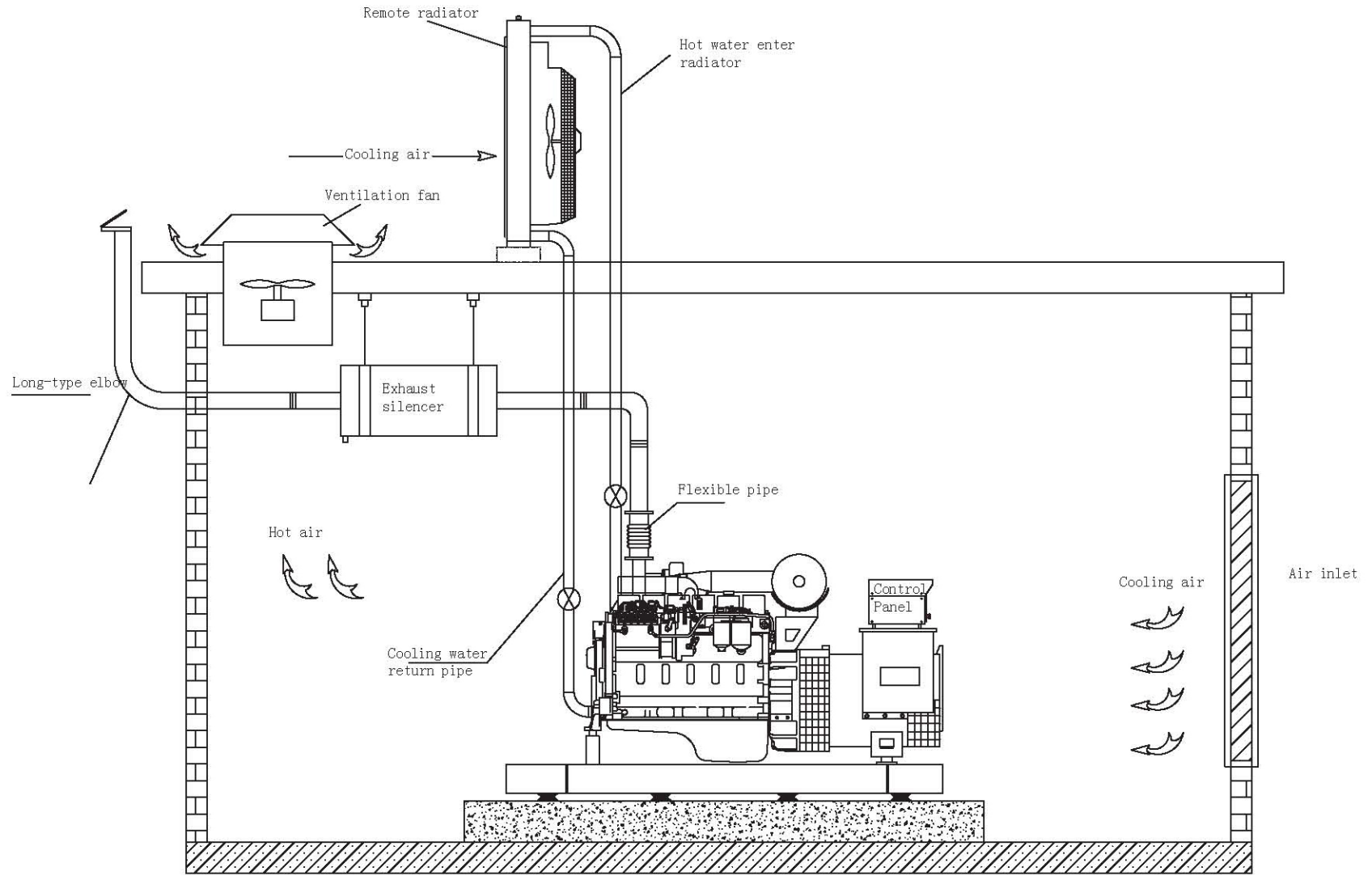

Heater exchange cooling system

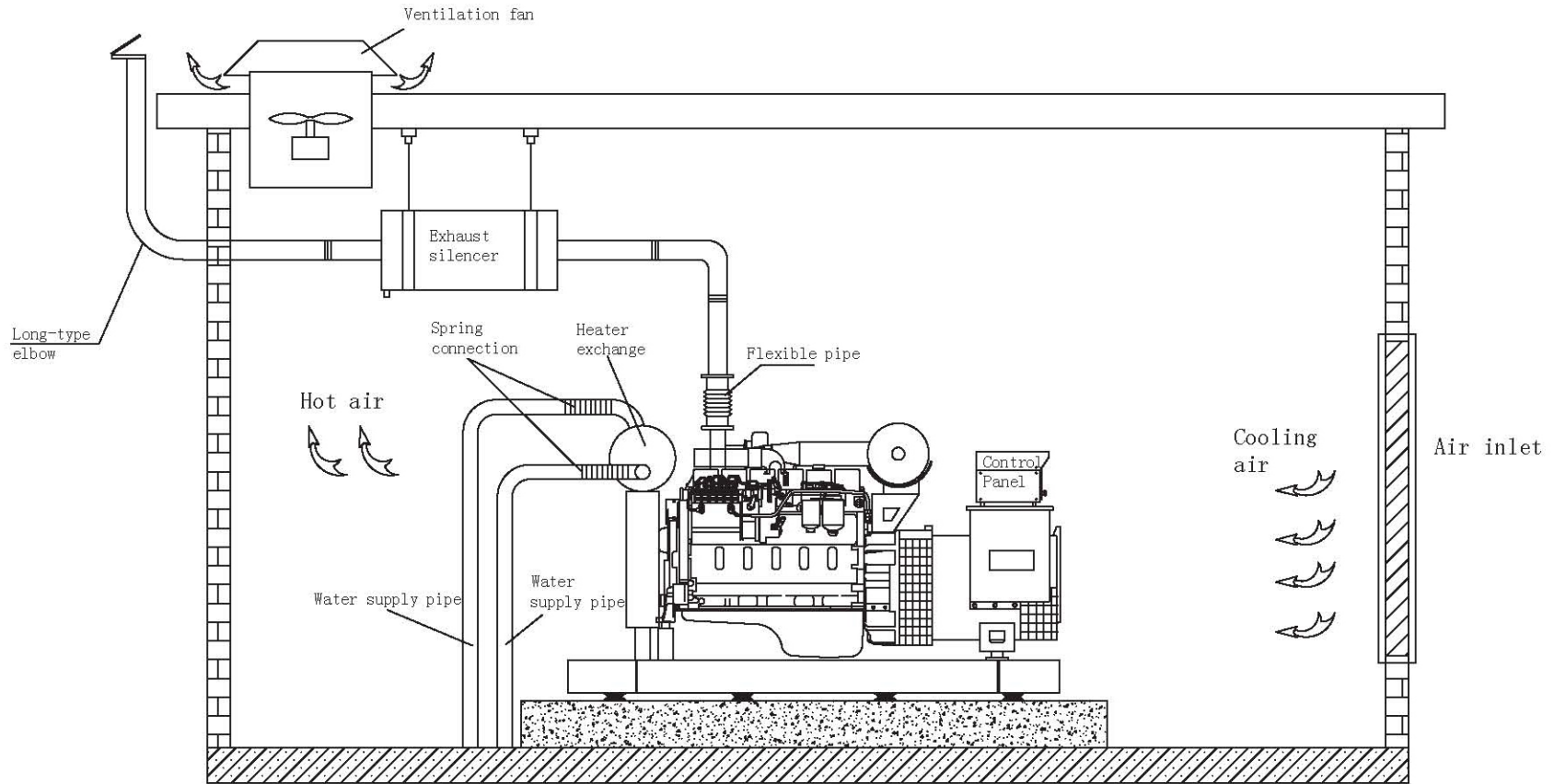

Typical exhaust system drawing

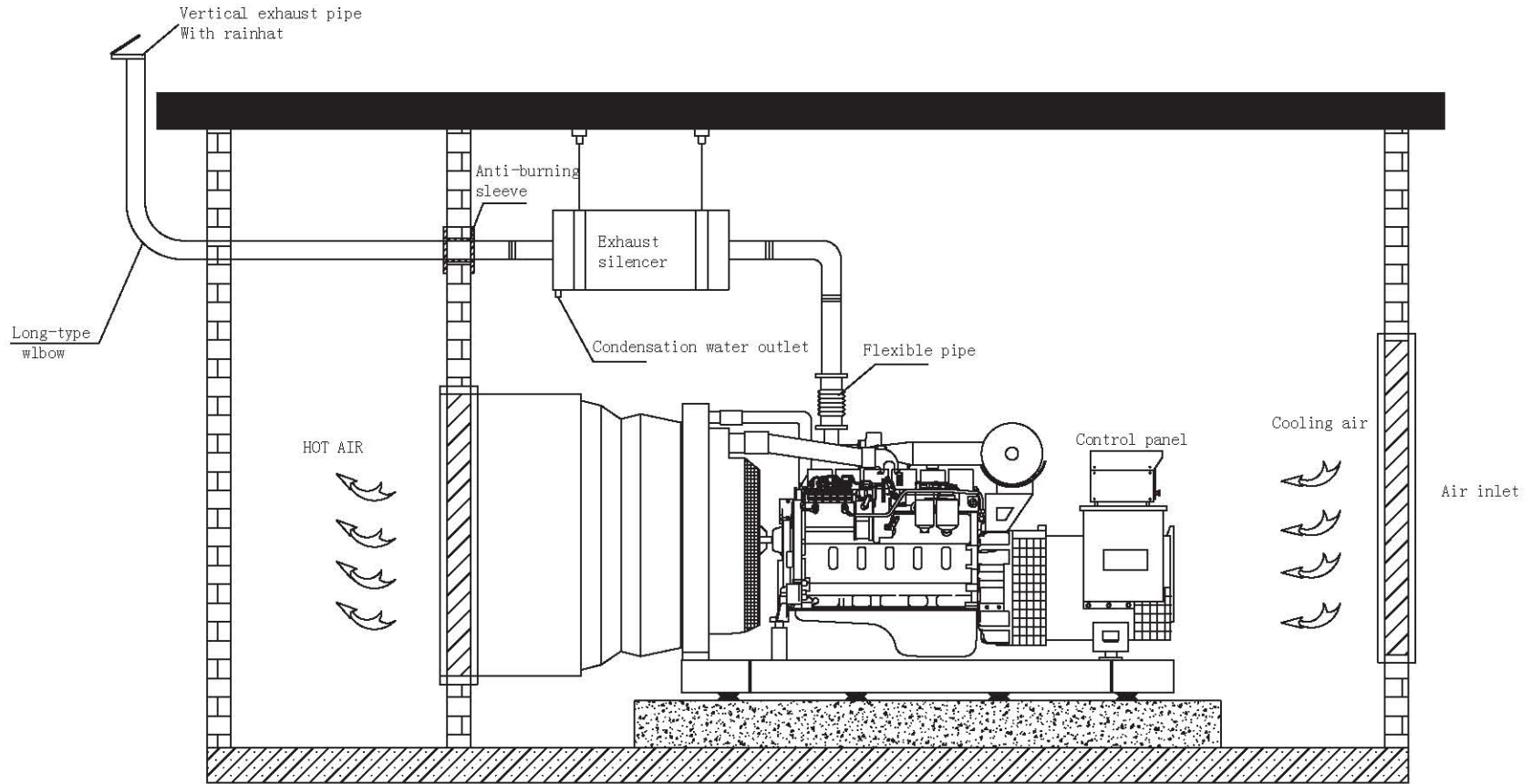

Double generators standard room drawing

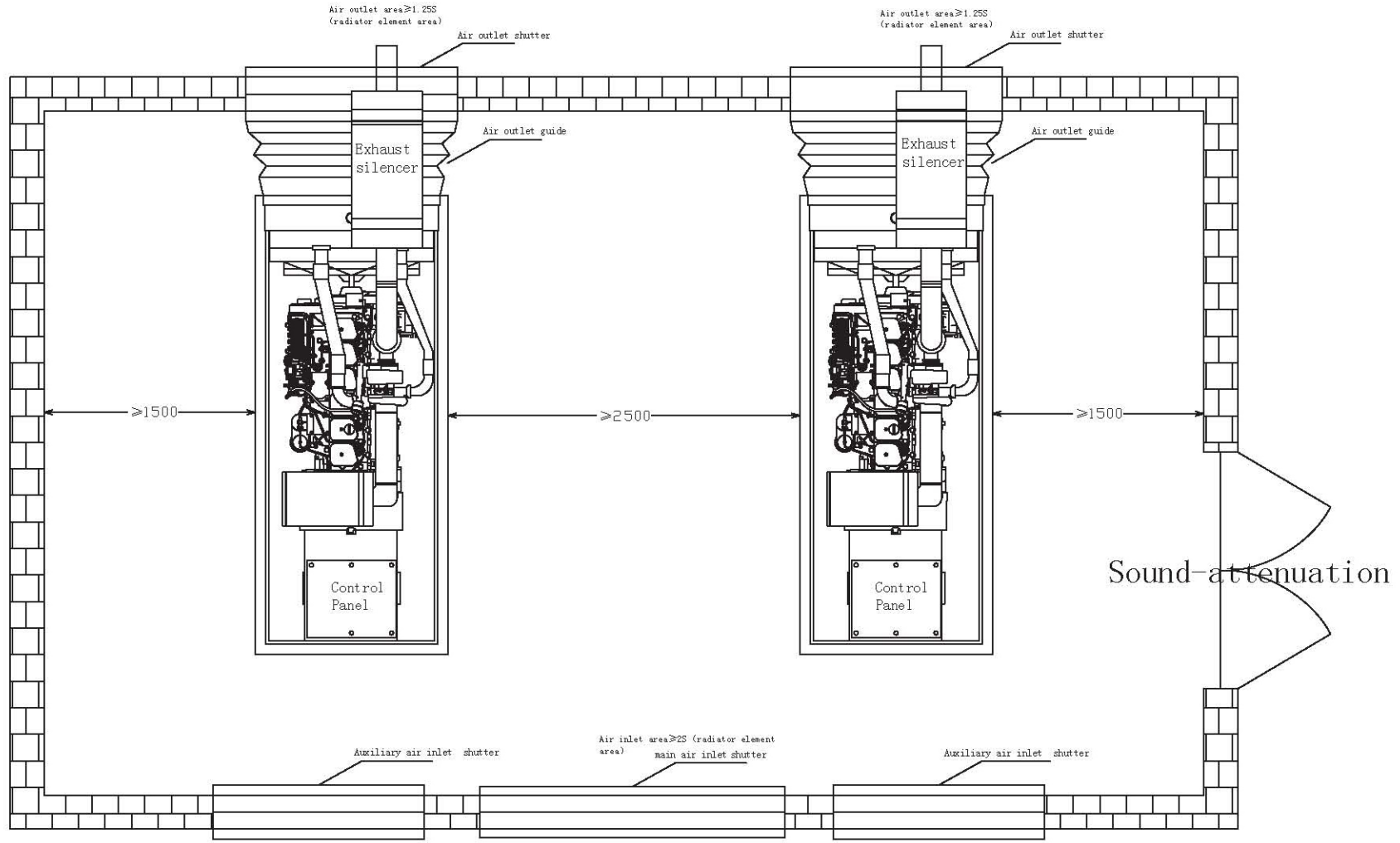

Single generator standard room drawing

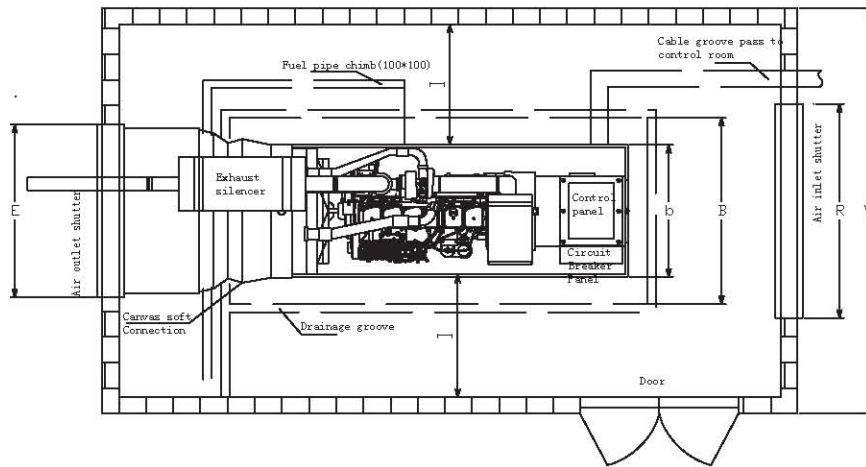
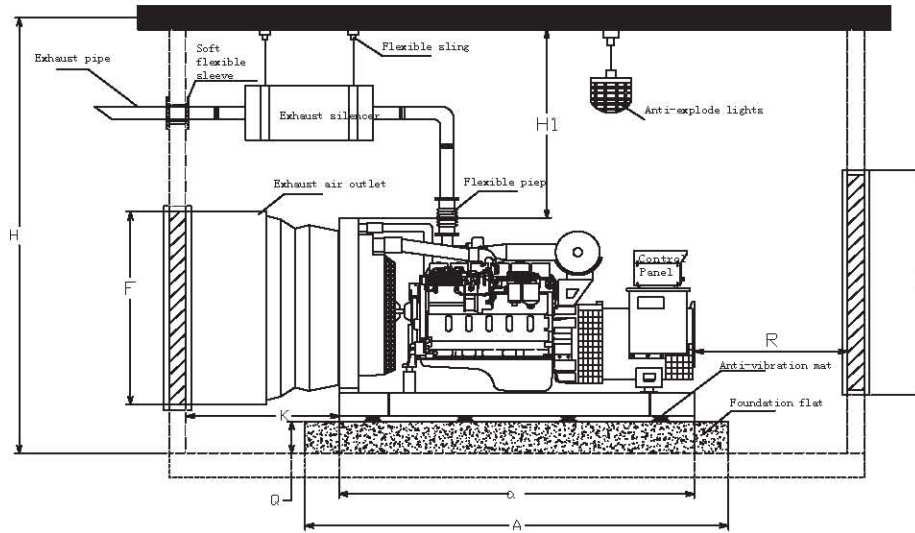

Technical notes

generator size (L×W)	a, b	
genset room recommended size (L×W×H)	A=K+e+I	B=2H+b C=J+Q+H1
foundation flat recommended size (L×W×H)	L=a+400mm W=b+400mm Q=3-4 times engine cylinder diameter	
Distance between genset and wall	I	>1500mm
	H1	>1500mm
	R	>1500mm
air pipe length	P<100KW	500mm
	100KW<P<400KW	600mm
	P>400KW	800mm
air outlet size	E×F	$S_{出}=E×F=1.25S_{\text{radiator element area}}$ with protection about ventilation quotient is 0.8, modification $S_{出}=1.25/0.8S_{\text{radiator element area}}$ E, F size proportion is same as radiator element E, F
air inlet area	S inlet	≥2S
Groove	width	200mm
	depth	250mm
cable chimb	width	P<100KW 400mm
		500KW<P<1000KW 500mm

Remarks: the above information is just for reference, for real project, you can call AOSIF, we will supply exact design based on your project, we will supply our advice on the foundation installation.

Generator set Vibration Isolation Foundation Scheme

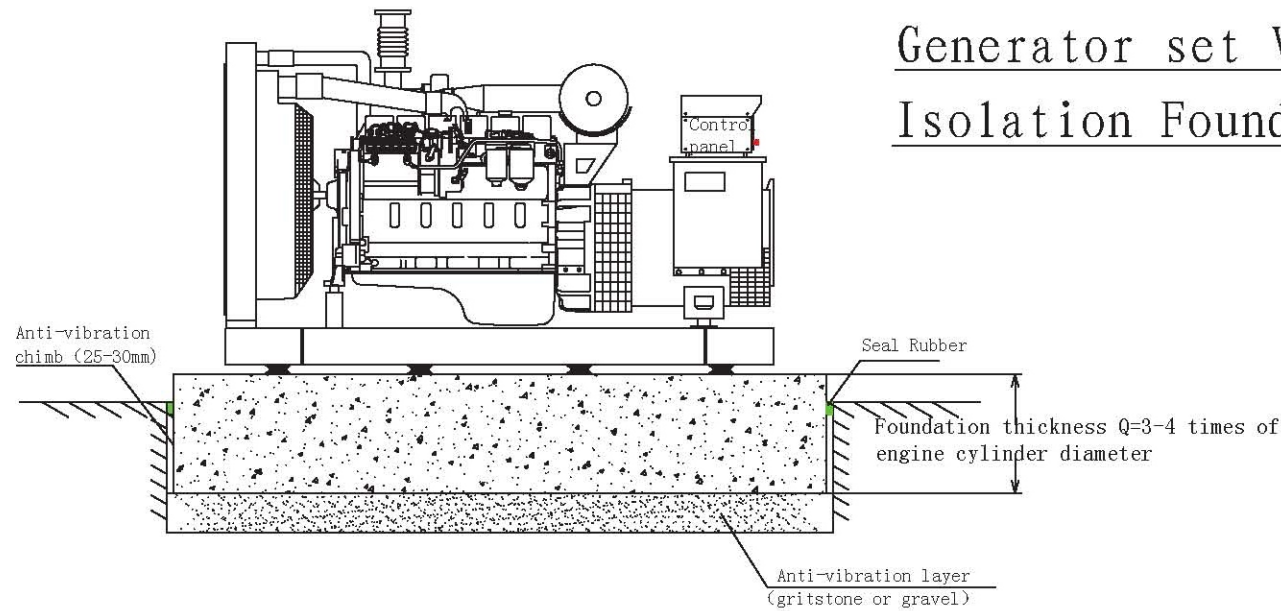

Technical notes:

- Basic foundation thickness is 3 or 4 times of engine cylinder, around the foundation, keep 25mm-30mm anti-vibration chimb with a sealed cover with rubber, in order to prevent water and oil leakage.
- The concrete cement:sand:carpolite proportion is 1: 2: 4, carpolite diameter is around 5-50mm;
- Generator set can only be installed 5 days after foundation finished.
- The foundation thickness and base bolt model and depth pls refer to the right forms.

Genset power P (KW)	Foundation thickness (mm)	Base bolt hole depth (mm)	Base bolt model
100<P<650	600	550	M16×500
650<P<2000	750	650	M20×600
Remote radiator	300	250	M16×300